



Diesel Care & Performance Inc  
"Care is at the center of everything we do"

1986 Chevy Truck Suburban 3/4 Ton 2WD V8-379 6.2L DSL

### Injection Pump Replace

Front cover to injection pump timing mark

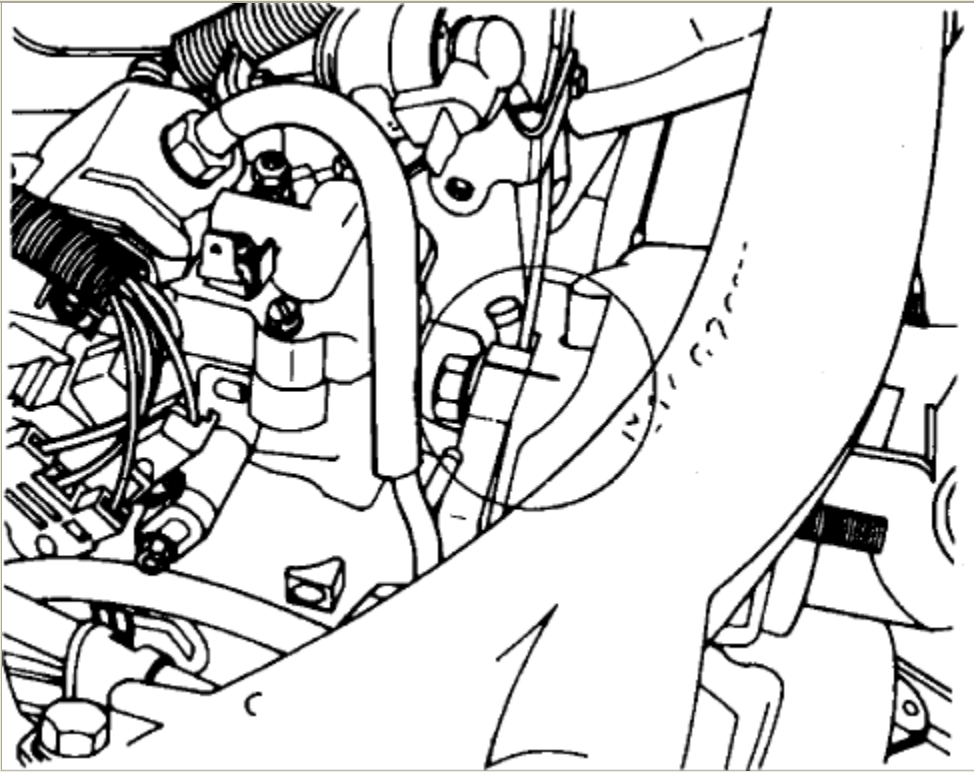

When installing injection pump on California models, ensure half circles align to form a complete circle. Any deviation in timing will result in the two half circles not matching. If a new injection pump is being installed, use the conventional timing marks,



Diesel Care & Performance Inc  
“Care is at the center of everything we do”

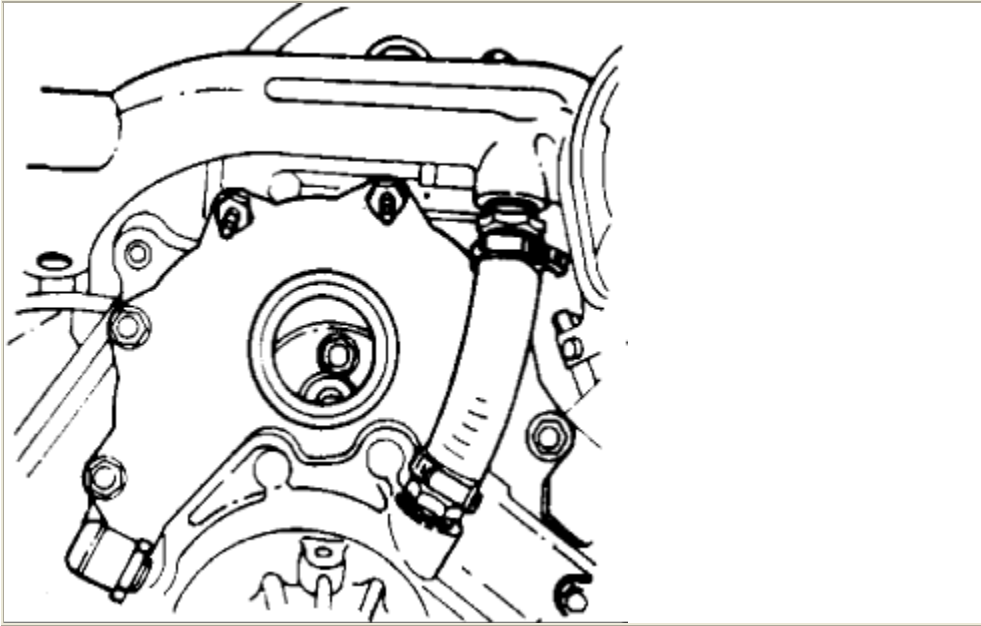

#### EXC. VAN Removal

1. Disconnect batteries and remove fan and fan shroud.
2. Remove intake manifold and fuel lines.
3. Disconnect accelerator injection pump. On models equipped with 700-4R auto. trans. also disconnect detent cable.
4. Disconnect fuel return line and remove wires and hoses from injection pump.
5. Remove fuel line from pump.
6. Remove A/C hose retainer bracket, if equipped.
7. Remove oil fill tube and PVC or CDRV vent hose assembly.
8. Scribe a mark on front cover and pump for alignment at reinstallation.
9. Rotate engine, as needed, to gain access to pump drive gear retaining bolts through oil filler opening, **Fig. 30**, then remove bolts.
10. Remove front cover to injection pump attaching nuts and remove pump. Cap all open lines and nozzles.

Front cover to injection pump timing mark



Diesel Care & Performance Inc  
*"Care is at the center of everything we do"*

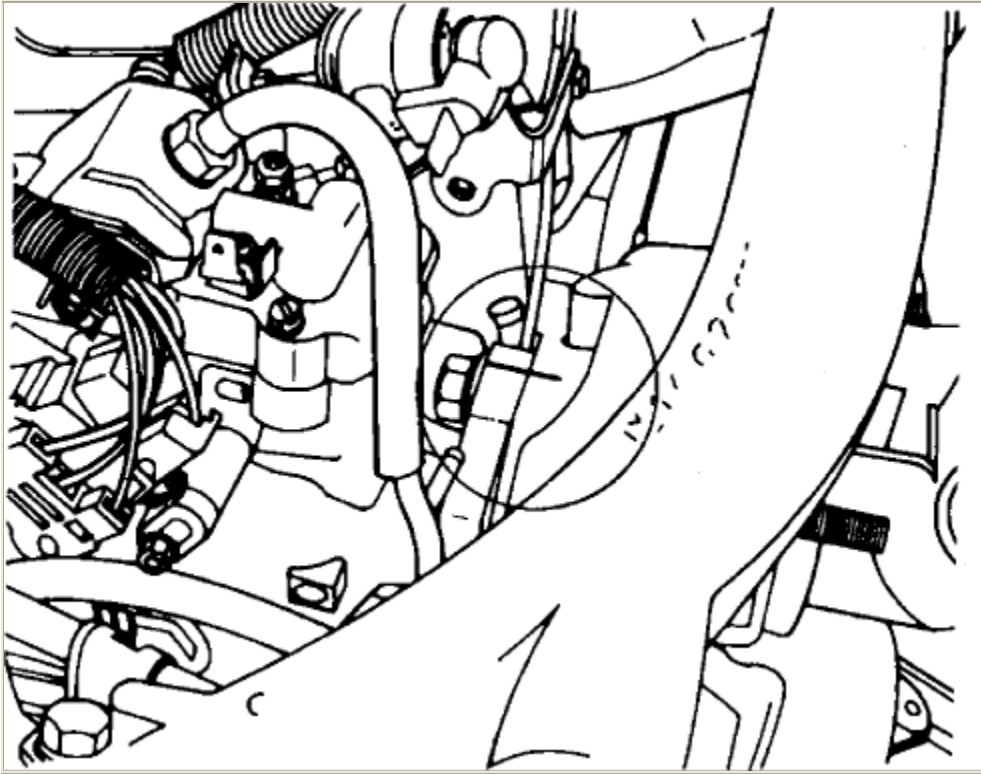

Injection pump locating pin



Diesel Care & Performance Inc  
"Care is at the center of everything we do"

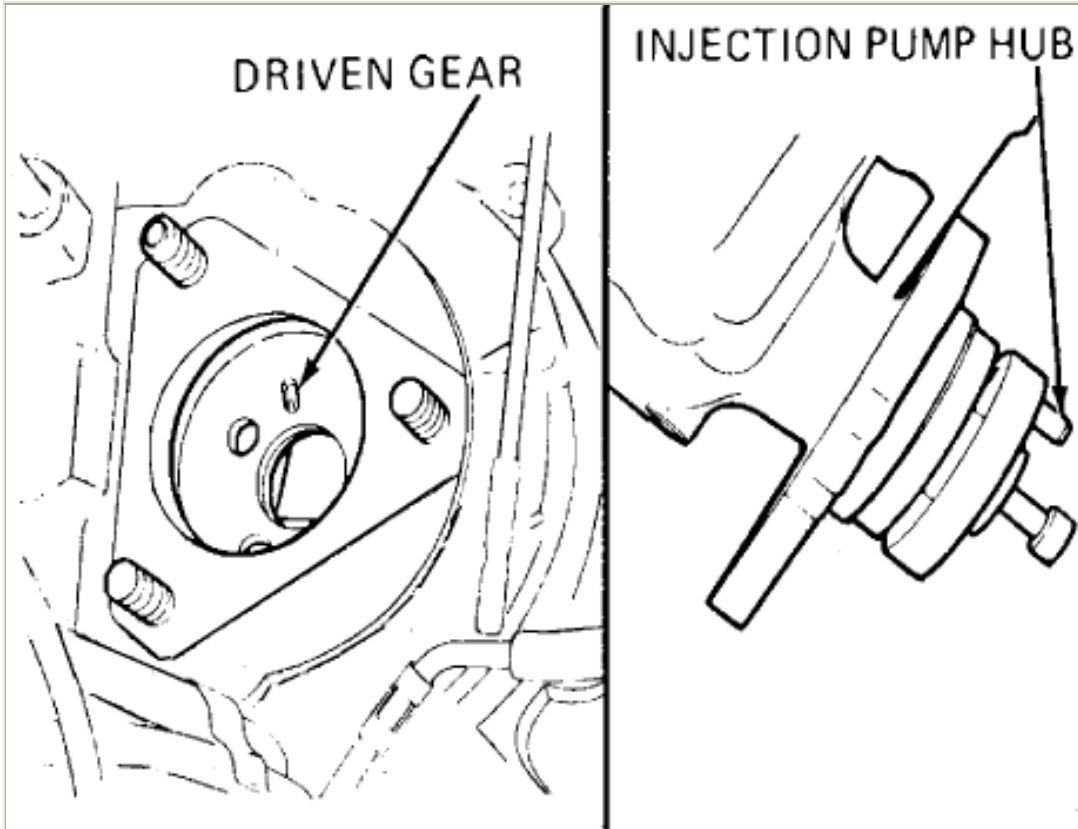

### Injection pump installation

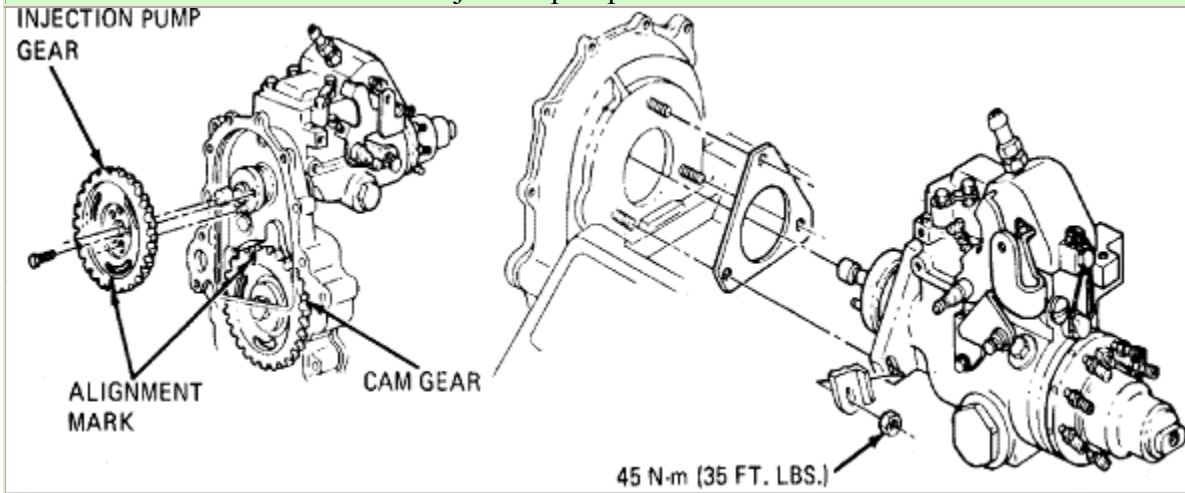

Installation

2740 Whitten Rd Bldg 103 Memphis, TN 38133  
Telephone 901-380-9290 Email Bwilliams@Dieselcare.net



Diesel Care & Performance Inc

*“Care is at the center of everything we do”*

1. Install new gasket. Align locating pin on pump hub with slot in injection pump gear, **Fig. 31**. Align scribe mark on front cover and pump and torque attaching nuts to 35 ft. lbs. on 1982---85 models, or 30 ft. lbs. on 1986---87 models, **Figs. 29 and 32**.
2. Install pump driven gear to pump and torque bolts to 20 ft. lbs.
3. Install oil fill tube and PVC vent hose assembly. Install A/C hose retainer bracket (if equipped).
4. Install fuel line at pump and torque to 20 ft. lbs.
5. Connect ul return line, accelerator cable, injection lines and necessary wires and hoses.
6. Install intake manifold, fan shroud and fan. Connect batteries.